

Australian Monitor

# AM3002

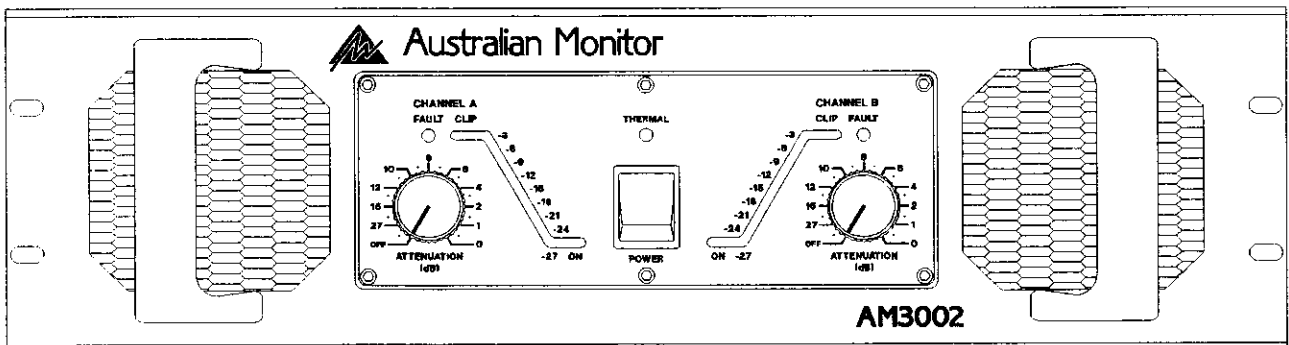

# Operation Manual

# IMPORTANT!

Please read carefully.

This operation manual contains important information regarding safety precautions, installation, performance, operation and maintenance of your AM3002 power amplifier. You should familiarize yourself with the contents of this manual **before** operating your amplifier.

## Safety Precautions and Labelling

The rear panel of the unit has a number of markings and internationally recognized symbols related to the hazards and precautions that should be taken when operating MAINS connected equipment.

The presence of a LIGHTNING FLASH with an arrowhead contained within the boundaries of an equilateral triangle is intended to alert the user that dangerous uninsulated voltages may exist within the unit's enclosure. These voltages may be of a sufficient magnitude as to constitute the risk of an electrical shock.

This symbol is reinforced with the text:

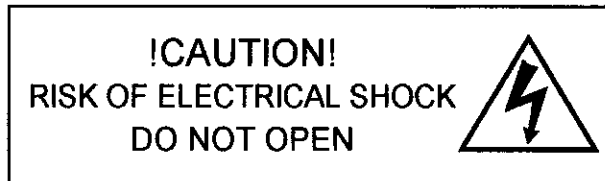

The presence of an EXCLAMATION MARK contained within the boundaries of an equilateral triangle is intended to alert the user that there is important operating and maintenance literature that accompanies the unit.



The unit should not be operated in a situation where it may encounter the entry of water, rain, or any fluids. To expose the unit to the above conditions may make the operation of the unit hazardous and increase the risk of electrical shock.

**REFER SERVICING TO  
QUALIFIED PERSONNEL.  
NO USER SERVICEABLE  
PARTS INSIDE.**

The user should not attempt to service the unit. Only qualified and knowledgeable personnel familiar with the internal workings of the unit should attempt any repair, servicing or authorized modification to the unit. The unit does not contain any parts which the user can service or re-use in this or any other product.

If you are in need of special assistance and the information you require is outside the scope of this manual, please contact your nearest service agent or Australian Monitor direct:

THE TECHNICAL OFFICER  
AUSTRALIAN MONITOR  
C/- AUDIOTELEX COMMUNICATIONS PTY LTD  
PRIVATE BAG 149,  
SILVERWATER. N.S.W. 1811  
AUSTRALIA.

	Phone	Fax
Local	(02) 9647-1411	(02) 9748-2537
International	61-2-9647-1411	61-2-9748-2537

Email	ho@audiotelx.com.au
Internet	www.australianmonitor.com.au



---

## Features:

- Custom designed, 3RU heavy duty alloy chassis.
- Modular construction.
- Symmetrical layout - even weight distribution.
- Linear, well-regulating, high current power supply.
- High efficiency toroidal mains transformer.
- Continuous high power capability.
- Double die - Lateral Mosfet Class AB output stage.
- Binding post and Neutrik "Speakon" output connections.
- Input signal strapping (loop through) connectors.
- Active balanced inputs.
- 21 Position detented attenuators.
- Massive heat-sink / heat-exchangers.
- Efficient front to back cooling.
- Quad, twin speed axial fans.
- Multi-role output fault indication.
- Front and rear carry handles.
- Front and rear mounting points.
- High-quality, close-tolerance components used throughout.

---

## Protection Features:

- Suppression of inrush current at mains turn-on.
- Side chain mains switching control.
- Input muting at turn-on.
- Input overvoltage protection.
- Radio-frequency interference suppression.
- Short-circuit protection and indication.
- Thermal overload protection and indication.
- Mains Circuit Breaker.
- Individual high current rail breakers.
- Layout, grounding, decoupling and componentry have been optimized to provide the user with **stability, reliability and longevity.**



# Contents

	Page
1. Introduction	5
2. Controls, Connectors and Indicators	6
2.1 Front Panel	7
2.2 Rear Panel	9
3. Installation	11
4. Operation	13
5. Bridge Mode	15
6. Two Ohm or Not Two Ohm	16
7. Maintenance	17
8. Warranty	18
9. Specification	19

## List of Illustrations

	Page
Figure 1. Block Diagram	5
Figure 2. Front Panel Layout	6
Figure 3. Rear Panel Layout	8
Figure 4. Case Dimensions	10
Figure 5. "Speakon" Connector Wiring	12
Figure 6. Bridge Mode Speaker Wiring	15



# 1. Introduction

Congratulations on choosing Australian Monitor for your professional amplification requirements.

The design of your AM3002 Audio Power Amplifier embraces all the aspects of a well designed unit. The visual design, mechanical, electrical and sonic parameters, along with our dedicated manufacturing process, have all been optimized to provide a professional tool that exhibits quality, reliability and longevity.

The AM3002 amplifiers are 3 unit (5.25") tall, 19" wide

rack mountable units.

Each channel of the amplifier comprises a balanced active input with an attenuator driving a differential class A drive stage which in turn drives a fan-cooled, class AB MOSFET output stage configured as a source follower. The unit operates from a high current capable linear power supply.

These units have been specifically designed to deliver their high power output with minimal distortion, and provide the critical degree of control required by your speakers, at high duty cycles for extended periods.

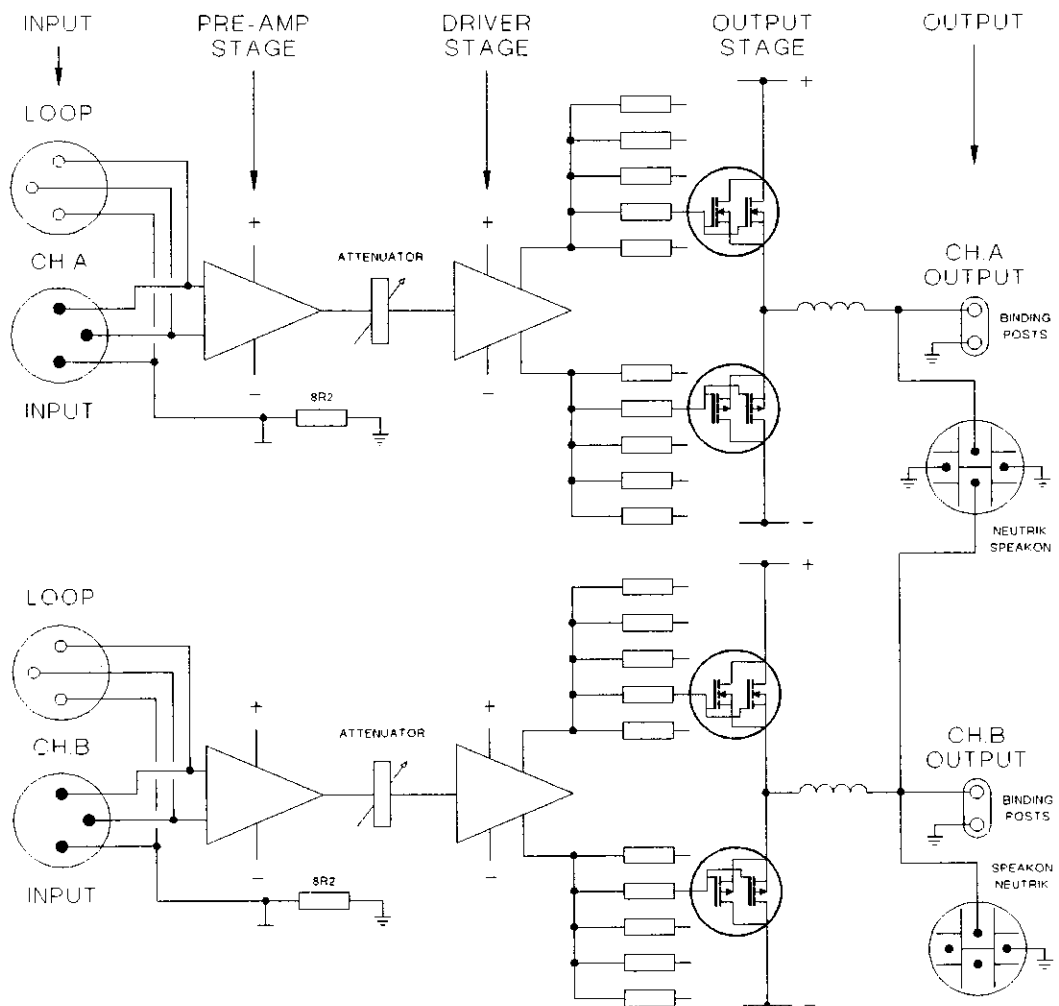

Figure 1 Amplifier Block Diagram



## 2. Controls, Connectors & Indicators

Insert - 1 VU Meter / Status Indicator

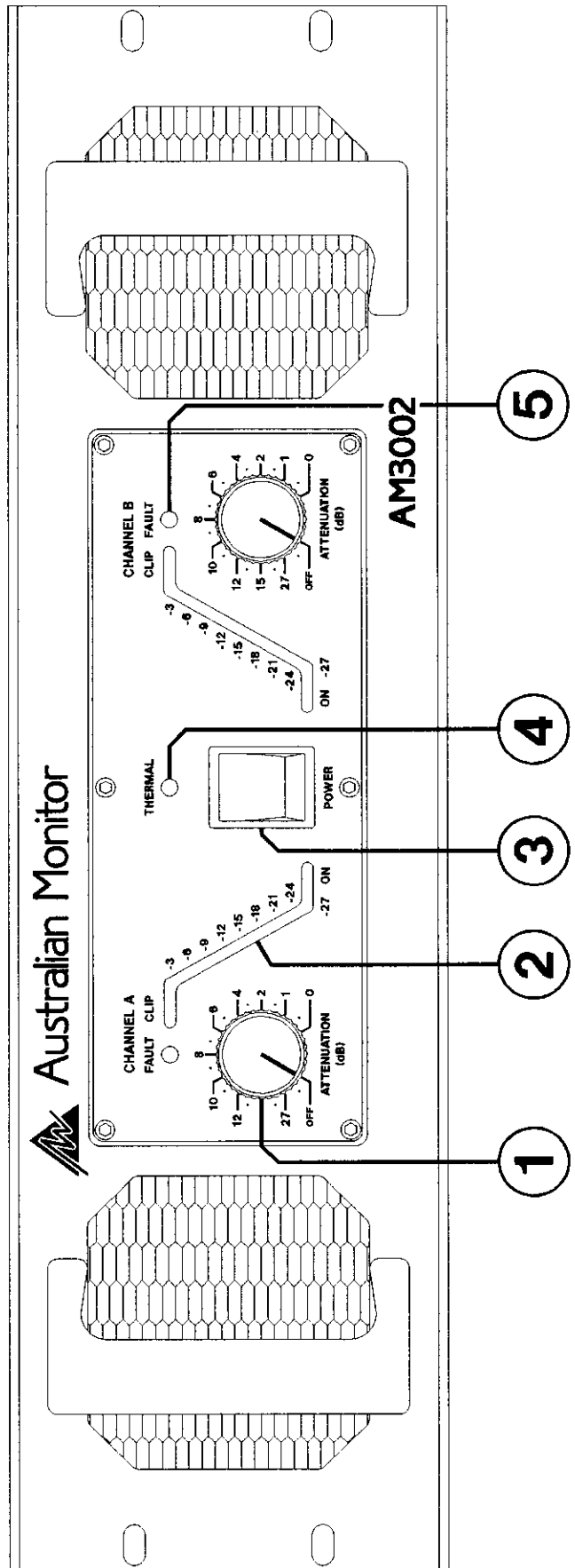
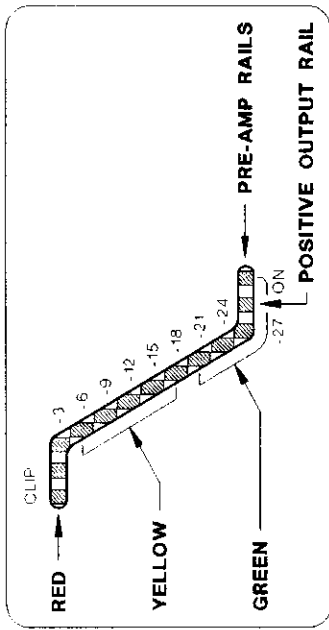

Figure 2 Front Panel Layout



## Front Panel

Figure 1 shows the panel layout of the AM3002. The functions of the controls and indicators are as follows:

### 1. Attenuator

Level control for your amplifier is provided by a 21 position detented potentiometer and indicates gain reduction in decibels from the 0 dB position (maximum gain, no attenuation).

### 2. VU Meter - Status Indicator

Level Indication (*see insert - 1*)

Each channel features a variable 10 segment display showing the actual power/volume level available before clipping (taking mains supply and load duty into account).

The display is colour coded, and calibrated in 3dB increments.

The 10 LEDs are:

Green	=	-27dB to -21dB
Yellow	=	-18dB to -6dB
Red	=	-3dB and the two LEDs indicating the clipping point.

### Power On Indication

Two Green LEDs either side of the mains switch (above the "ON" legend) are used to indicate that the unit is on. The first Green LED indicates the 15 Volt preamp supply is present (the left hand side display shows -15V, and the right hand side shows the +15V).

The next LED outwards is also a supply indicator and shows that the Positive High Current Output Rail is available to the corresponding channel.

NOTE: The amplifier is not damaged by running into clipping, but speakers may be. To maximise the life of your speakers, try to keep clipping infrequent.

### 3. Power Switch

Press the switch **DOWN** for power **ON** and **UP** for power **OFF**. At start-up (turn-on) the input to the amplifier is muted by 30dB for approximately two seconds.

### 4. Thermal Indicator

When switching the amplifier on, this red LED will flash momentarily, indicating correct operation of the Mains In-Rush Current Suppression circuit.

After establishment of Inrush Current Suppression circuit the LED will extinguish. This LED will not illuminate during normal use of the amplifier.

In the advent of a thermal overload this LED will illuminate **red** indicating that the internal operating temperature of one or both amplifier channels has exceeded a safe level of operation and the amplifier will be shut down. The fans will continue to run and once the amplifier has cooled down sufficiently, the amplifier will start up automatically providing Inrush Current Suppression and input signal muting until establishment of the amplifier after which it will return to normal operating mode.

NOTE: You should always ensure that the fan grille is kept clean and free from the build up of dust and lint. This will ensure longer operation of your amplifier and reduce the possibility of it prematurely going into thermal shutdown mode.

### 5. Fault Indicator

This amber LED will illuminate when a fault condition exists.

The fault detection circuit monitors the difference between drive and output in your amplifier.

If you have a short circuit on the speaker output (or a blown negative rail fuse) the LED will flash brightly in sync with the programme. This LED will also flash with programme peaks for gross overloads or if the load is 2 ohms or less.

The circuit has two stages of operation:

1. It will provide indication (e.g. gross overload) but does not affect the input signal (a faint flash).
2. It will indicate and mute the input signal (e.g. shorted output) (brightly flashing or permanently on).

In the advent of a failure the display panel reverts to a fault display to assist in diagnosis of the fault.

- The VU meter will light up fully and the Positive Output Rail LED will extinguish if the positive supply rail is not available (check rear rail breaker).
- The fault Led will glow brightly if the Negative Output Rail is not available (check rear rail breaker).
- Failure of the pre-amp supply will cause the amplifier to be muted and indicator LEDs to be extinguished



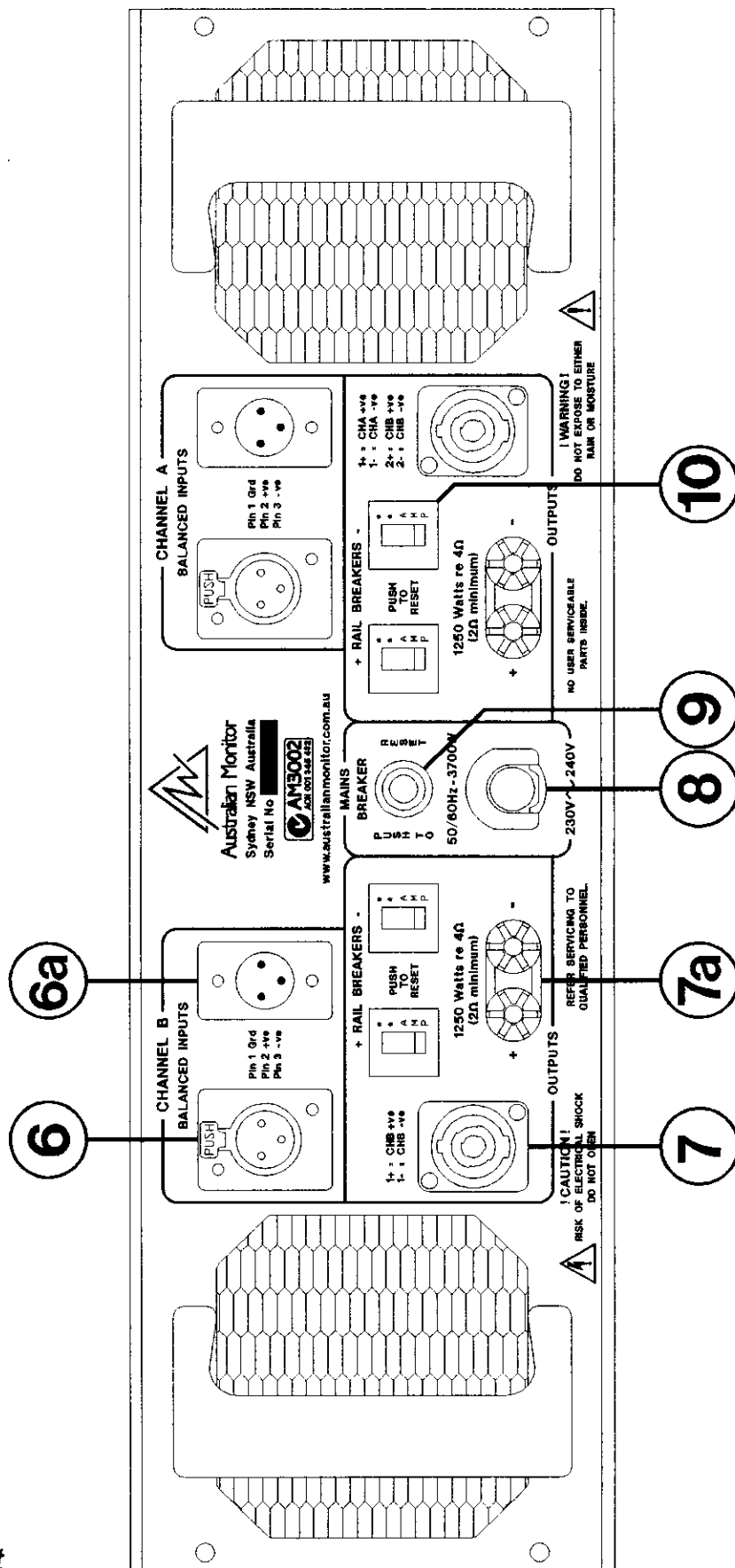

Figure 3 Rear Panel Layout





## Rear Panel

### 6. Balanced Input

A female 3-pin XL type connector is provided on each input:

- Pin 1 = Signal Ground;
- Pin 2 = Hot (non-inverting or in phase);
- Pin 3 = Cold (inverting or reverse phase).

### 6a. Signal Strapping

A male 3-pin XL type connector is provided and wired in parallel with the female input XLR for strapping / looping signal between amplifiers.

### 7. SPEAKON Output Connector

The NEUTRIK (NL4MP) 4 way SPEAKON connector is provided as the main speaker output termination. This emerging standard of loudspeaker to amplifier connection allows access to both channels of the amplifier via the one connector for bi-amp applications. Channel-A is considered the dominant channel and has both channels wired to the Speakon connector. See the installation section of this manual for detailed information on Speakon wiring.

### 7a. Binding Post Outputs

Binding posts (banana jacks) are provided for speaker output termination with banana plugs or bare wire. The red post is used as **positive** and the black post is used as **negative**.

### 8. Mains Lead

Your amplifier is supplied with a heavy duty mains lead (power cord) appropriately rated for the mains supply voltage marked on the rear panel of your amplifier.

The wires in the mains lead are coloured in accordance with the following code:

**BROWN = ACTIVE;**  
**BLUE = NEUTRAL;**  
**GREEN AND YELLOW = EARTH.**

## **! CAUTION !**

**Your amplifier must always be earthed!**

### 9. Mains Circuit Breaker

A "push to reset" thermal acting circuit breaker is supplied on your amplifier providing overall protection of your amplifier's power supply and the interconnecting mains. The breaker will isolate the "active" mains conductor in the event of a high current internal fault or in continued overload conditions.

The breaker will not be able to be reset immediately after tripping. A cool down period of around 30 seconds is required before the breaker will reset back into circuit. If the breaker "trips" immediately after a reset, then a fault may have developed within the amplifier.

### 10. D.C. Rail Breakers

Your AM3002 amplifier is fitted with 15 Amp thermal acting circuit breakers as overload protection for the output stage of your amplifier.

These breakers are in series with the high current supply rails to the amplifier's output stage and will "trip" when:

- 1) An internal fault exists;
- 2) There is a sustained overload;
- 3) There is a sustained short circuit;
- 4) There is a sustained load fault.

Front Panel Indication will result if one of the corresponding Rail Breakers is to "trip".

- The VU meter will light up fully and the positive Output Rail LED will extinguish if the positive supply Rail Breaker "trips".

- The Fault Indicator will light up and pulse in sync. with the program source if the negative supply Rail Breaker "trips".



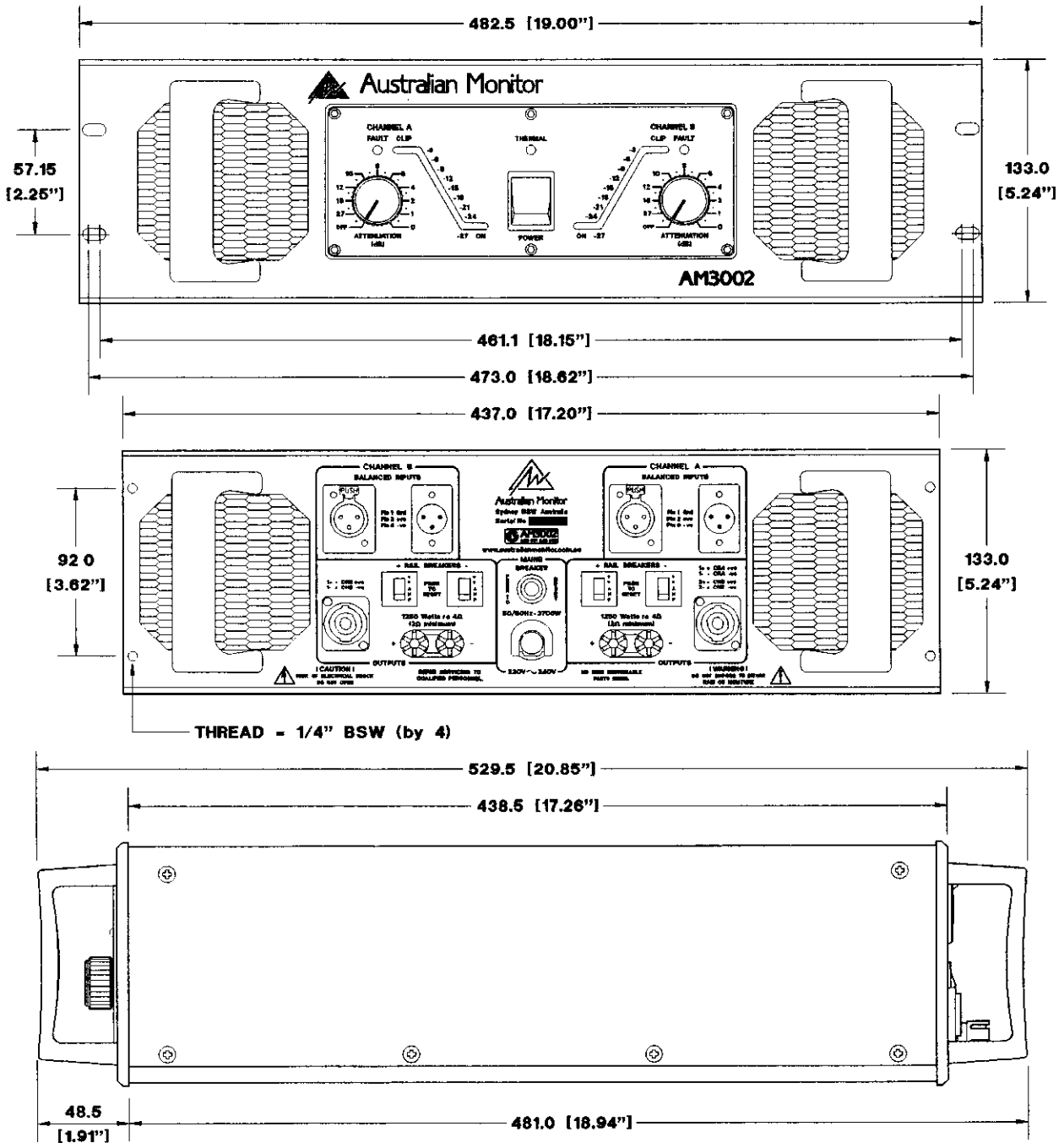

Figure 4 Dimensions



## 3. Installation

### Mains Lead Wiring

#### WARNING

**Your amplifier must be earthed at all times!**

When you first receive your amplifier it may not have a mains plug attached. You must ensure that an appropriate plug is used and corresponds with the amplifier's current (ampere) requirements and meets the approval of your local energy authority.

**Please refer termination of this lead to qualified personnel. Australian Monitor takes no responsibility for any damage or harm resulting from improper termination of this lead!**

The wires in the mains lead are coloured in accordance with the following code:

#### GREEN AND YELLOW = EARTH

Connect to the terminal marked with the letter E, with the EARTH SYMBOL or coloured GREEN.

#### BLUE = NEUTRAL

Connect to the terminal marked with the letter N (or coloured WHITE in USA and Canada, or coloured BLACK in the United Kingdom).

#### BROWN = ACTIVE (LIVE)

Connect to the terminal marked with the letter A or L (or coloured BLACK in USA and Canada or coloured RED in the United Kingdom).

### Power Requirements

Mains Voltage	Circuit Breaker Rating
100 to 120 volts	40 Amps
220 to 240 volts	20 Amps

Power Consumption at idle = 500 Watts  
Consumption at rated 4 ohm power = 3700 Watts

Ensure that **your** mains voltage is the same as the rear panel mains voltage marker (+/- 10%).

### Mounting

Your amplifier is designed for standard 19" rack mounting and occupies 3 EIA rack units (5.25"). The mounting centres are:

Vertical: 2.25" (57.15mm)  
Horizontal: 18.15" (461.1mm) to 18.62" (473.0mm).

The slots in the mounting flange will accept bolt diameters up to 1/4" (6.35mm).

We recommend that you provide additional support for the amplifier, especially if road use is planned, as the weight can bend some racks otherwise. This support can be provided by secure shelving, support rails or a rear rack mounting strip to match up with the rear rack mount points provided on your amplifier.

### Cooling

Each channel of your AM3002 amplifier is cooled by two axial fans which draw cool air from the front of the unit and expel the heated air from the rear of the unit. These units offer two speed fans which run at half speed, switching to full speed when the internal heatsink temperature exceeds 60°C (128°F).

An unrestricted airflow into and out from the unit must be provided. Any restriction of the air flow will cause heat to build up within the unit and possibly force the unit into its thermal shutdown mode.

If the units are to be operated in an environment where the airflow is restricted such as sealed racks or even when running 2 ohm loads, the cooling should be supplemented by extra cooling fans to evacuate the heated air and aid the flow of cool air through the unit.

### Input Wiring

**IMPORTANT!** Do not directly connect pin 1 on the amplifier's input or strapping XLR, to the amplifier's chassis, speaker ground or power ground!

**NOTE: Input signal ground is not to be used as a safety ground (earth).**

The input to your amplifier is a balanced 3-pin system and requires all three pins to be connected. Only high quality twin-core shielded cable should be used.

When wiring for a balanced source the connector going to the input of your amplifier should be wired as follows:

Pin 2 = HOT (In Phase - non inverting).  
Pin 3 = COLD (Reverse Phase - inverting).  
Pin 1 = GROUND / SHIELD.

When wiring from an unbalanced source you must ensure that pin 3 is connected to pin 1 (input ground), either by linking the pins in the input connector or by the source equipment's output wiring.

When wiring for an unbalanced source:

Pin 2 = HOT (in phase with the amplifier's output),  
Pin 3 = GROUND / SHIELD (joins to pin 1).  
Pin 1 = GROUND / SHIELD



**NOTE:** In-line XLR connectors often have a termination lug that connects directly to the chassis of the connector. Do not link this lug to pin 1 at the amplifier's input as it will defeat the amplifier's input grounding scheme. This lug is often referred to as a "drain" and is used to provide a termination to the chassis for shielding purposes when a floating signal ground is required between the source and destination, or when disconnecting the signal ground is required to reduce earth loop noise, or noise induced into signal grounds from stray magnetic fields.

## Output Wiring

When wiring to your speakers always use the largest gauge wire your connector will accept. The longer the speaker lead the greater the losses will be, resulting in reduced power and less damping at the load. We recommend using a heavy duty two core flex (four core flex if bi-amping) 10 to 12 gauge (2mm<sup>2</sup> to 2.5mm<sup>2</sup> or 50/0.25 or equivalent) as a minimum.

## Binding Post Outputs

When terminating to the 4 mm binding post (banana jack) output connectors, banana plugs or bare wires can be used. The red terminal is **positive** and the black terminal is **negative** (ground).

If running in BRIDGE mode, only the **red** binding posts are used. Channel A provides the positive output to the load and channel B provides the negative output to the load.

## SPEAKON Outputs

When using the NEUTRIK SPEAKON (NL4MP) connector for speaker output, use only the mating NEUTRIK NL4FC in-line connector. This connector is designed so that both channels can be fed from a single connector.

Two SPEAKON connectors are provided on the amplifier. The "Channel A" SPEAKON actually carries both channel A & channel B outputs (see *Figure 5: Speakon Connector Wiring Diagrams*).

The "Channel B" SPEAKON carries the Channel B output only.

This arrangement allows you the option of connecting to the outputs separately or together. Connecting through a single connector has the advantage of minimising connections, preserving phasing and simplified channel allocation, which is particularly important when **bi-amping** or in **bridge** mode.

### IMPORTANT

Do not overload your amplifier by connecting the channel B output twice!

Channel A is used as the "dominant" channel and when sourcing a dual output from Channel A the following standard should be used:

- Channel A = Left or Low Frequencies.
- Channel B = Right or High Frequencies.

### When in bridge mode:

- Pin 1+ = Bridge Output Positive.
- Pin 2+ = Bridge Output Negative.

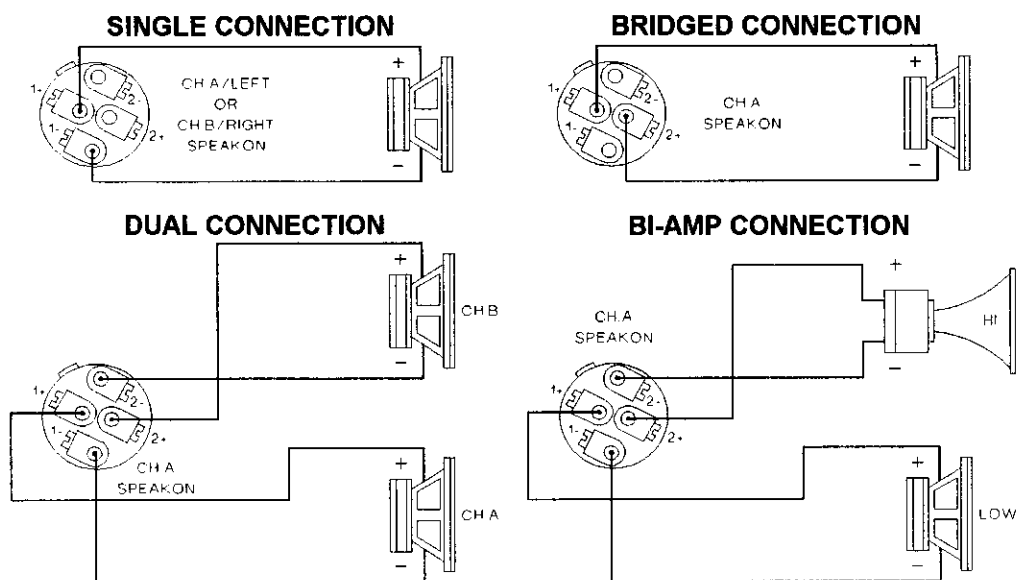

Figure 5. "Speakon" Connector Wiring Diagram



## 4. Operation

### IMPORTANT

All signal source equipment should be adequately earthed. This not only ensures **your** safety but everybody else's as well. Faults can and do occur in mains connected equipment where the chassis can become "live" if it is not properly earthed. In these instances the fault in a "floating" (un-grounded) piece of equipment will look for the shortest path to ground which could possibly be your amplifier's input. If the fault current is large enough it will destroy the input to your amplifier and look for the next available path, which **may be you!**

**Before making any connections** to your amplifier observe the following:

1. Ensure the mains voltage supply matches the label on the rear panel of your amplifier (+/- 10%).
2. Ensure that the power switch is OFF (UP)
3. Ensure that all system grounds (earths) are connected from a common point. Avoid powering equipment within a system from multiple power sources that may be separated by large distances.
4. Check the continuity of all interconnecting leads to your amplifier, ensure that there are no open or short circuited conductors.
5. Ensure that the power handling of your load (speakers) can adequately cope with the power output of the amplifier.

### Very Important

Due to the high power ability of the AM3002 you need to be aware that certain precautions need to be followed to ensure longevity of your amplifier:

- **Never** turn your amplifier on unless all connections (inputs and speakers) have been made!

- **Never** plug in a signal lead after the amplifier has been turned on! Turn the unit off first.

- **Never** drive the output into clipping if the load is open circuit or there is no speaker load connected!

## Powering Up

### REMEMBER

The amplifier should be the **last** piece of equipment that you turn **on** and the **first** piece of equipment that you turn **off**.

We recommend turning the attenuators on your

amplifier **down** when turning the unit on.

When you power up your amplifier, your amplifier goes through an establishment period before it will accept signal. The Inrush Current Suppression (ICS) circuit is in operation for the first 0.5 seconds. This limits the mains current to prevent "nuisance tripping" of circuit breakers.

During this period the THERMAL LED will flash **red** whilst the mains voltage gradually charges up the power supply. You will then hear dual relays "click", indicating mains is now directly applied to the amplifier.

While the ICS circuit operates there is also a 30dB mute on the signal input. After two seconds this mute will release, allowing any applied signal to pass unattenuated.

When switching the amplifier off, **wait** a couple of seconds before switching the unit on again. This allows the ICS circuit to reset.

## Level Matching

The normal operating position for the attenuator is the "0 dB" position (fully clockwise, no attenuation). In this position the amplifier operates at full gain. Turning the attenuator back (anticlockwise) reduces the input sensitivity by the amount marked on the attenuator scale (dial).

NOTE: If full power output is required you should operate your amplifier with the front panel attenuator above the -15dB position, otherwise clipping of the input circuitry and its resultant distortion will occur before full output power is achieved.

## Sensitivity

Your amplifier is a linear device operating with a fixed input to output voltage gain (less attenuation). The maximum output voltage swing is determined by the applied mains voltage, load, load type and the duty cycle of the applied signal.

The voltage gain factor of your amplifier is: **63.5 times** or **36dB**.

The **input sensitivity** for your amplifier when the attenuator is at the "0" dB attenuation position (fully clockwise) is nominally:

**+3.3dBu** (1.14volts in) for rated power into a 8 ohm load.

**+2.2dBu** (1.00 volt in) for rated power into a 4 ohm load.



Each channel of your amplifier has a nominal balanced **input impedance of 25k Ohms (@1kHz)** and should not present a difficult load for any signal source.

Your signal source (i.e. the equipment feeding the amplifier) should have an **output impedance of 600 Ohms or lower** to avoid unwanted high frequency loss in the cabling.

Input overload occurs at +20.5dBu (8.25 volts). See the specification section for more detailed information.

### Hum Problems

Most equipment is designed for minimum hum when used under ideal conditions. When connected to other equipment, and to safety earth in an electrically noisy environment however, problems will often occur.

The three "E"s of hum and hum related noise which can plague your audio system are:

- a) Electrostatic radiation,
- b) Electromagnetic radiation, and
- c) Earth loops.

**Electrostatic** radiation capacitively couples to system elements causing an interference voltage that mainly affects higher impedance paths, such as amplifier inputs. The source is generally a nearby high voltage such as a mains lead or a speaker lead. The problem can usually be reduced by moving the offending lead away, or by providing additional electrostatic shielding (i.e. an earthed conductor which forms a barrier to the field).

**Electromagnetic** radiation induces interference currents into system elements that mainly effect lower impedance paths. Radio transmitters or stray magnetic fields from mains transformers are often the cause of this problem. It is generally more difficult to eliminate this kind of interference, but again, moving the source away or providing a magnetic shield (i.e. a steel shield) should help.

**Earth loops** can arise from the interfacing of the various pieces of equipment and their connections to safety earth.

This is by far the most common cause of hum, and it occurs when source equipment and the amplifier are plugged into different points along the safety earth where the safety earth wiring has a current flowing in it. The current flowing through the wire

produces a voltage drop due to the wire's resistance. This voltage difference between the amp earth and source equipment earth appears to the amplifier's input as a signal and is amplified as hum.

There are three things you can do to avoid earth loop problems:

1. Ensure your mains power for the audio system is "quiet" i.e. without equipment on it such as air-conditioning, refrigeration or lighting which may generate noise in the earth circuit.
2. Ensure all equipment within the system shares a common ground/ safety earth point. This will reduce the possibility of circulating earth currents as the equipment will be referenced to the same ground potential.
3. Ensure that balanced signal leads going to the amplifier are connected to earth at one end only.

### Signal Ground Lifting

When proper system hook-up has been carried out, you may still have some hum or hum related noise. This may be due to any of the previously mentioned gremlins.

One of the most effective ways to reduce earth loop or electromagnetically induced hum is to disconnect input signal ground at the input connector of your amplifier. This effectively breaks the earth loop path or open circuits the input ground path so no electromagnetically induced currents can flow through the amplifier.

NOTE: If the input signal ground is lifted you must ensure adequate shielding of the input wiring. If the signal source equipment does not provide adequate shielding (i.e. a definitive connection to ground) you must disconnect the shield from the input connector's ground pin (Pin-1) and reconnect it to the "drain" contact on the input connector. This will ensure the shield on your input wiring actually goes to the amplifier chassis and subsequently to earth.

**DO NOT CONNECT PIN-1 DIRECTLY TO THE DRAIN CONNECTION.**

You will defeat the amplifiers internal grounding scheme and possibly cause instability within the amplifier.

This should only be done when the amplifier is operated from a **balanced** signal source.

NOTE: Be wary of **quasi-balanced** outputs, these are often no more than floating **unbalanced** outputs.



## 5. Bridge Mode

The term BRIDGE is used when two independent amplifier channels are used to drive the same load. The load is in series (a bridge) between the two amplifier channels.

Channel A is used as the "dominant" channel and its output is **in phase** with the input signal, and channel B has to have its phase reversed so it is exactly 180° **out of phase** with the input signal.

As two amplifiers with a phase difference of 180° are now driving the load you will now have double the voltage into the load. This means you will now have four times the power into that load. The output can now be considered as an **active balanced output**.

A common use of an amplifier in BRIDGE mode is for driving 70 volt & 100 volt distribution lines. In BRIDGE mode, The AM3002 can produce in excess of 140 volts into line impedances greater than 8 ohms.

Equally the units can be used in bridge mode to provide the correct voltage/power requirements for an applicable load.

As shown in *Figure 6*, there are four steps in setting up your AM3002 amplifier for running it in BRIDGE mode. Whilst the amplifier is **off**,

1. Connect the signal source to the Channel-A female input XLR.

2. Loop from Channel-A male XLR to Channel-B female input XLR with a Reverse Phase Lead.

A reverse Phase Lead is wired:

Channel-A	Channel-B
Pin-1 to	Pin-1
Pin-2 to	Pin-3
Pin-3 to	Pin-2

3. Connect your load between the **red** binding post output terminals, where the **positive** side of the load is connected to the Channel-A output and the **negative** side of the load goes to the Channel-B output. There are no further connections required.
4. Turn the attenuators on both channels fully clockwise (0dB - no attenuation).

You can also source the output from the Channel-A SPEAKON output connector where Channel-A will be on the pin marked 1+ and Channel-B will be on the pin marked 2+.

NOTE: You should check after market manufactured Speakon interconnecting speaker leads before connecting them to your amplifier. Some leads are manufactured for specific purposes, or specific use, and may have pins shorted inside the connector. Any speakon lead with shorted pins will obviously short the output of your amplifier (either to ground, or output to output - be careful).

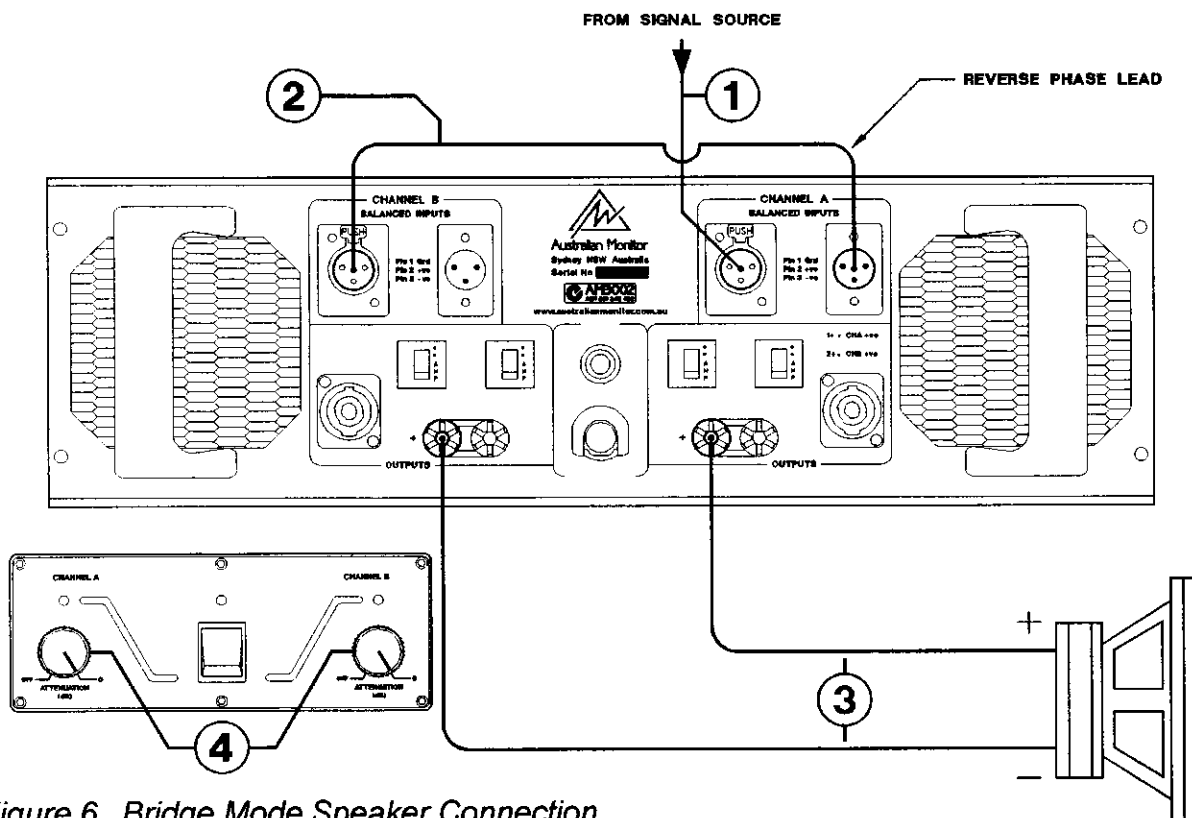

Figure 6 Bridge Mode Speaker Connection



## 6. Two Ohm or Not Two Ohm

NOTE: Ensure adequate ventilation and monitor the FAULT indicators to guard against thermal shutdown when driving two ohm loads.

### A preamble.

The load that a loudspeaker presents to an amplifier is very complex and at different frequencies can be inductive, capacitive, resistive, or a combination of these (reactive). With the complex interaction of these attributes, which alter from loudspeaker to loudspeaker, a definitive load for an amplifier does not really exist.

Loudspeakers operating within an enclosure are specified with a **nominal** impedance. This nominal impedance is only a rough guide to the load it presents to an amplifier.

As an example, a loudspeaker with a nominal impedance of say 8 ohms, may have an impedance of over 50 ohms at resonance (bass frequencies), drop to less than 6 ohms after the resonance peak (through its mid band area) and then increase to over 16 ohms for higher frequencies.

A 4 ohm load makes an amplifier work "harder" than an 8 ohm load at the same voltage, as double the current is required.

Though various loudspeakers may be marked with the same nominal impedance, some loads are more difficult than others.

**Bass** frequencies usually exhibit higher impedances and require higher voltages to achieve the desired result. They also reflect higher energy back to the amplifier simply due to the amount of cone excursion involved at lower frequencies.

The **Mid** frequency band usually offers the lowest impedances and the highest duty cycles requiring both high voltage and high current.

The **High** frequency region usually offers a moderate impedance and usually does not need much voltage but the instantaneous current demand can be much greater than you think.

As well as this burden on the amplifier, the transient waveforms found in actual use can demand a lot more current than the "steady-state" sinewaves used in most amplifier bench tests.

The power output of your AM3002 amplifier quoted on the specification sheet is derived from a voltage

excursion into a resistive load for a sine wave at a given frequency. Though this method is in line with the various standards that exist, it only gives an indication to the maximum voltage swing (before clipping) for a given load. This method of rating power does not give an indication of the current (Ampere) capability of the amplifier, nor does it show the amplifier's ability to sustain high energy waveforms.

Your AM3002 amplifier has been specifically designed to be able to deliver more than twice the current than that shown on the specification sheet to cope with difficult loads and/or high energy waveforms.

This extra current reserve is the result of over engineering and is the headroom the amplifier utilizes to control the loudspeaker and deal with the "reactive energy" from the loudspeaker load that has to be dissipated within the amplifier.

Your AM3002 amplifier is able to drive 2 ohm loads or operate in BRIDGE mode into 4 ohms. The operator must be aware that when driving 2 ohm loads or bridged 4 ohm loads that the currents running in the output stage are very large and will cause greater heat build up within the amplifier than higher impedance loads.

The **Front Panel FAULT Indicators** can be used to provide an indication of the "difficulty" of the load and will give the operator an indication of the heat build up in the output stage.

If the fault indicators flash with the "clip" LEDs or do not illuminate until well into clipping then the load can be considered as normal or easy.

If the fault indicator starts to flash before the "clip" LEDs then the load should be considered complex and/or difficult.

For the more complex and/or difficult loads, the illumination of the "fault" LED on programme peaks should be interpreted as the **output level limit**. Driving the output continuously past this point could result in muting of the output stage, breakers tripping or premature thermal shutdown.

The fault detection circuit is also thermally compensated, and fault indication will occur earlier when the unit is hot. If the "fault" LED continually lights earlier than normal, then the unit is heating up. If the signal level is not reduced to compensate for the heating of the unit then thermal shutdown may occur.





## 7. Maintenance

Your AM3002 amplifier will need minimal maintenance. No internal adjustments need to be made to the unit to maintain optimum performance.

To provide years of unhindered operation we suggest a maintenance inspection be carried out on a regular basis, say every 12 months or so.

### Fans

Due to the openness of the air path through your AM3002 amplifier, very little dust should settle within the amplifier. The unit has been designed so that any dust and/or foreign particles that do settle within the amplifier will not unduly hinder the cooling of the unit.

The mesh grille in front of the fans will act to limit the amount of dust and lint entering the unit. You will find in time that there will be a build up of dust and lint on the grille which may start to hinder the airflow through the unit. You should periodically remove the dust and keep the grille clean.

Over time, dust may build up on the leading edge of the fan blades and reduce their cooling efficiency. The time taken for this to happen will depend on the environment and the amount of use.

The fan blades are accessible once the lids are removed and can be easily cleaned. You need only hold the fan rotor still and wipe the dust off the blades. Many users **stall** the fan and use compressed air to blow the dust off the fan blades. It is important to note that the fan blades must be held still whilst blowing air over the blades otherwise you may burn out the bearings in the fan.

#### NOTE:

Make sure the unit is **off** and is unplugged from the mains. Give the main filter capacitors time to discharge before removing lids.

Only **competent** or **qualified** persons should attempt any service or maintenance of your amplifier!



# 8. Warranty

Australian Monitor warrants the original purchaser of each AM3002 amplifier (purchased at an authorised Australian Monitor dealer) that it will be free from defects in materials and workmanship for a period of two (2) years from the original date of purchase.

Australian Monitor will, at its option, repair or replace any unit or component covered by this warranty which becomes defective or malfunctions under normal use and service during the period of this warranty, at no charge for parts or labour to the original owner.

**This warranty does not cover thermal problems due to obstructed airflow, or defects or malfunctions resulting from accidents, misuse, abuse, operation with the incorrect AC mains voltage, connection to faulty equipment, modification or alteration without prior factory approval or service by unauthorised personnel.**

It is the owner's responsibility to ensure that normal maintenance inspections are carried out at regular intervals as recommended in the maintenance section of this manual. Australian Monitor reserves the right to refuse warranty service where the owner fails to

take reasonable care in use and maintenance of the amplifier.

To validate this warranty, the original purchaser must complete and mail the warranty registration card directly to Australian Monitor within fourteen (14) days of purchase.

To obtain warranty service, the equipment should be shipped to an authorised Australian Monitor dealer or direct to Australian Monitor. Freight to Australian Monitor is at the owner's expense.

Units with a defaced serial number will not be accepted for warranty service. Any evidence of alteration, erasure or forgery of the purchase receipt will also void this warranty.

**Australian Monitor accepts no liability for any consequential damages, whether direct or indirect, arising from the use or misuse of its products.**

Australian Monitor reserves the right to alter its designs and specifications at any time without notice or obligation to previous purchasers.



## Australian Monitor

### AM-SERIES 2 YEAR WARRANTY REGISTRATION

#### IMPORTANT

Please complete this card and return it immediately after unpacking the product.

This card is to be sent **DIRECTLY** to Australian Monitor.

**NOTE!** Warranty is effective **ONLY** upon receipt of this card.

COMPANY \_\_\_\_\_

NAME \_\_\_\_\_ MODEL \_\_\_\_\_

ADDRESS \_\_\_\_\_ SERIAL N° \_\_\_\_\_

\_\_\_\_\_ DATE PURCHASED \_\_\_\_\_

CITY \_\_\_\_\_ DEALER \_\_\_\_\_

STATE \_\_\_\_\_ CODE \_\_\_\_\_ COUNTRY \_\_\_\_\_

*Ensure that you fill out and send your warranty registration card.  
Use this copy to record a duplicate of the details.*



EIA Output Power @ 1kHz 0.1% / 1.0% THD + N (in watts)

	8 ohm	4 ohm	2 ohm
Single Channel	680 / 720	1,200 / 1,290	<b>1,860 / 2,010</b>
Both Channels	630 / 675	1,080 / 1,150	1,600 / 1,730
Rating (AVG)	670	1,180	<b>1,800</b>
Bridged	2,125 / 2,250	3,200 / 3,460	—————

Output Power 20Hz to 20kHz @ 1% THD + N (in watts)

	8 ohm	4 ohm	2 ohm
Single Channel	675	1,100	<b>1,750*</b>
Both Channels	650	1,000	1,600*
Bridged	2,175	3,250*	—————

\* = 15kHz Sweep Limit

Tone Burst IHF - 202 (20 cycles @ Clip, 480 Cycles @ -20dB re 1kHz)

	8 ohm	4 ohm	2 ohm
Single Channel	—————	1,320	<b>2,200</b>
Both Channels	—————	1,230	2,000
Bridged	>2,450	> <b>4,000</b>	—————

Distortion (0.5 dB below clipping re 4 ohms)

THD+N (@ 1 kHz) <0.01%  
 IMD SMPTE (60 Hz & 7 kHz 4:1) <0.02%  
 IMD DIM 30 (3.15kHz square & 15 kHz) <0.03%

Output Impedance @ 1 kHz <0.020 ohms

Damping Factor @ 1 kHz re 8 ohms >400:1

Output Rise Time <3.0µS  
 (80%, leading edge of 20kHz square wave)

Slew Rate >50V per µS  
 (leading edge, 20kHz square wave @ clipping)

Frequency Response

20 Hz - 20 kHz < ± 0.25 dB  
 -3dB points <10 Hz - 80 kHz

Input Impedance Line to Line (Balanced) 30k

Input Sensitivity (nominally)

For rated power re 8 ohm 1.14 Vrms (+3.3 dBu)  
 For rated power re 4 ohm 1.0 Vrms (+2.2 dBu)

Voltage Gain 63.5 times (36 dB)

Input CMRR

@ 1 kHz (re 8 ohm rating) >90 dB

Signal / Noise ratio

"A" weighted (re 8 ohm rating) >106 dB

Crosstalk @ 1 kHz (re 8 ohm rating) >90 dB

Weight Net 70.5 lb (32kg), Shipping 77.0lb (35.5kg)

Dimensions

H x W x D  
 excluding handles 133 x 483 x 445 (mm)  
 including handles 133 x 483 x 530 (mm)  
 (19 inch EIA rack mounting, 3 units high)

Test conditions

Input source = 600 ohm, Balanced and ground referenced (CMRR test had floating ground & 50 ohm source). Mains regulated to 240 volts / 50hz. All measurements taken at binding post output terminals. Standard production units measured. No compensation applied.



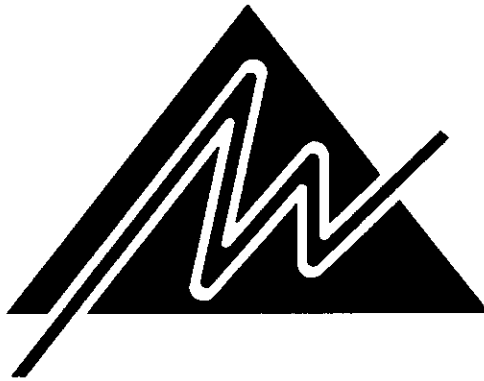

# Australian Monitor

[www.australianmonitor.com.au](http://www.australianmonitor.com.au)

Distributed by:

**Audio Telex Communications Pty Ltd**

ACN001345482

[www.audiotelx.com.au](http://www.audiotelx.com.au)

International Enquiries

Ph: 612 9647 1411, Fax: 612 9748 2537, E-mail: [ho@audiotelx.com.au](mailto:ho@audiotelx.com.au)

**Sydney**

Ph: (02) 9647 1411, Fax: (02) 9648 3698, E-mail: [nsw@audiotelx.com.au](mailto:nsw@audiotelx.com.au)

**Melbourne**

Ph: (03) 9890 7477, Fax: (03) 9890 7977, E-mail: [vic@audiotelx.com.au](mailto:vic@audiotelx.com.au)

**Brisbane**

Ph: (07) 3852 1312, Fax: (07) 3252 1237, E-mail: [qld@audiotelx.com.au](mailto:qld@audiotelx.com.au)

**Adelaide**

Ph: (08) 8352 4444, Fax: (08) 8352 4488, E-mail: [sa@audiotelx.com.au](mailto:sa@audiotelx.com.au)

**Perth**

Ph: (08) 9228 4222, Fax: (08) 9228 4233, E-mail: [wa@audiotelx.com.au](mailto:wa@audiotelx.com.au)

**Auckland**

Ph: (09) 415 9426, Fax: (09) 415 9864, E-mail: [audiotlx@nznet.gen.nz](mailto:audiotlx@nznet.gen.nz)

