

PMD1 & PMD1S

Handheld Microphone

Congratulations on purchasing your new Australian Monitor microphone.

The PMD1 and PMD1S premium dynamic supercardioid microphones feature neodymium motors with aluminium voice coils, ensuring super-fast transient response. Both models also feature an isolation transformer which ensures RF and electrical noise isolation. The incorporated capsule isolation system keeps handling noise to a bare minimum. While the PMD1 and PMD1S are tailored for vocal reproduction, both models can also be used to reproduce instruments as well.

These premium microphones are highly recommended for presentations, stage vocal performance, instrument reproduction, percussion reproduction, and many other applications.

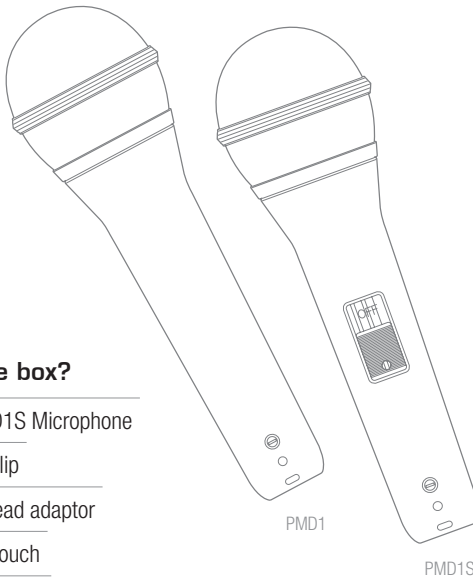

What's in the box?

1 x PMD1 or PMD1S Microphone

1 x Microphone Clip

1 x 5/8 – 3/8 thread adaptor

1 x Microphone Pouch

The instruction manual
you are now reading

Features

Supercardioid polar pattern

High SPL operation

Exceptional gain before feedback

Low handling noise

Transformer Isolated

Magnetic lockable reed switch
(PMD1S only)

Rugged design

USING YOUR PMD1 OR PMD1S

Connecting your Microphone

The PMD1 and PMD1S microphones accept an XLR Female 3 pin connector. The XLR pin out required for correct polarity is Pin 2 + , Pin 3 – and Pin 1 shield.

Phantom power is not required for these dynamic microphones to operate. If your mixing console features global phantom power don't worry, the PMD1 and PMD1S microphones contain isolation transformers which block phantom power.

Loudspeaker Monitor Positioning

To ensure maximum gain before feedback, as well as crosstalk reduction, position loudspeaker monitors in the null of your microphone's supercardioid pick pattern. Positioning the loudspeakers at 120°–135° behind the microphone will ensure you are in the microphone's greatest null point (see Figure 1).

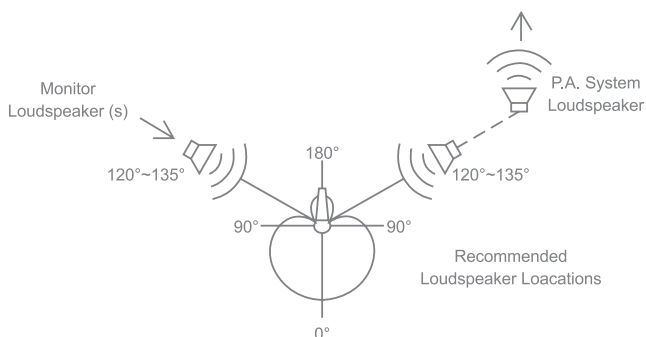

LOUDSPEAKER MONITOR POSITIONING (Figure 1)

Proximity effect

Due to their capsule design, many microphones feature what is known as proximity effect. Essentially the closer the talent is to the microphone when performing or speaking the more low frequency content is reproduced. Many stage performers use the proximity effect as part of their act by increasing and decreasing the distance of the microphone from their mouth depending on what phrases and/or words they are performing. Female vocalists in particular take advantage of the proximity effect to increase the low frequency content in their vocals.

A rough guide of microphone distance and controlling the proximity effect is as follows:

0 – 4 cm = Very strong low frequency content.

Provides a powerful and direct sound with little external noise spill.

4 – 10 cm = Neutral pickup response and balanced sound, however the microphone may pick up some room ambience and possibly spill from other sound sources.

10 > cm = A reduction in bass response. Much greater room ambience will be pickd up and possibly a large amount of unwanted spill from other sound sources may be reproduced.

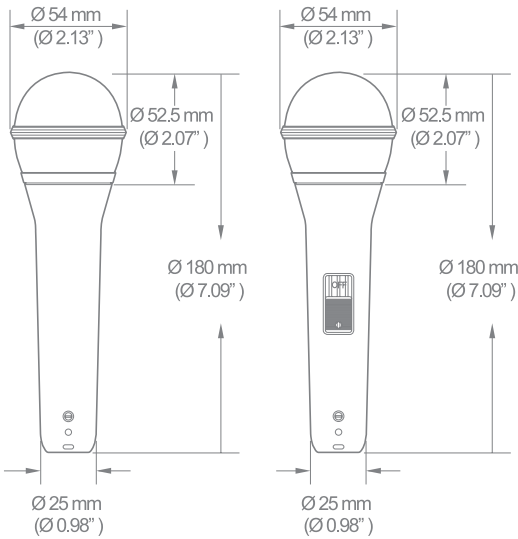

PMD1 < DIMENSIONS >

PMD1S

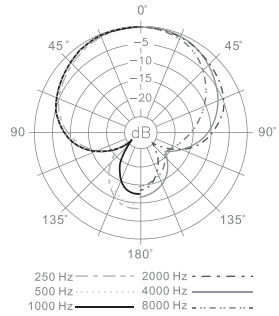

TYPICAL POLAR PATTERN

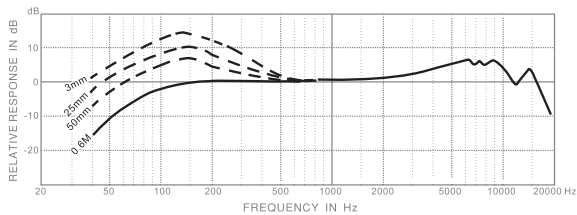

TYPICAL FREQUENCY RESPONSE

Specifications

Transducer Type	Dynamic – Neodymium, aluminium voice coil with dual diaphragm
Polar Pattern	Supercardioid
Frequency Response	40Hz – 16KHz
Sensitivity	2 mV/Pa -54 dBV
Electrical Impedance	300 Ω
Min. Load Impedance	300 Ω
Max. SPL	136dB @ 1% THD
Finish	Matte Black
PMD1S Switch	Magnetic silent lockable reed switch
Connection	Balanced 3 pin XLR Male Pin 2 +, Pin 3 -, Pin 1 shield
Dimensions	Ø54mm x L 180mm
Net Weight	340g
Included Accessories	Microphone clip, 5/8 – 3/8 thread adaptor, microphone pouch

IMPORTANT SAFETY INFORMATION

1. Read these instructions.
2. Keep these instructions.
3. Heed all warnings.
4. Follow all instructions.
5. Do not use this apparatus near water.
6. Clean only with dry cloth.
7. Do not block any ventilation openings. Install in accordance with the manufacturer's instructions.
8. Do not install near any heat sources such as radiators, heat registers, stoves, or other apparatus (including amplifiers) that produce heat.
9. Do not defeat the safety purpose of the polarized or grounding-type plug. A polarized plug has two blades with one wider than the other. A grounding type plug has two blades and a third grounding prong. The wide blade or the third prong are provided for your safety. If the provided plug does not fit into your outlet, consult an electrician for replacement of the obsolete outlet.
10. Protect the power cord from being walked on or pinched particularly at plugs, convenience receptacles, and the point where they exit from the apparatus.
11. Only use attachments/accessories specified by the manufacturer.
12.  Use only with the cart, stand, tripod, bracket, or table specified by the manufacturer, or sold with the apparatus. When a cart is used, use caution when moving the cart/apparatus combination to avoid injury from tip-over.

13. Unplug this apparatus during lightning storms or when unused for long periods of time.
14. Refer all servicing to qualified service personnel. Servicing is required when the apparatus has been damaged in any way, such as power-supply cord or plug is damaged, liquid has been spilled or objects have fallen into the apparatus, the apparatus has been exposed to rain or moisture, does not operate normally, or has been dropped.
15. This appliance shall not be exposed to dripping or splashing water and that no object filled with liquid such as vases shall be placed on the apparatus.
16. Plug this apparatus to the proper wall outlet and make the plug to be disconnected readily operable.
17. Mains plug is used as disconnected device and it should remain readily operable during intended use. In order to disconnect the apparatus from the mains completely, the mains plug should be disconnected from the mains socket outlet completely.
18. Warning: To reduce the risk of fire or electric shock, do not expose this apparatus to rain or moisture.
19. An appliance with a protective earth terminal should be connected to a mains outlet with a protective earth connection.
20. The apparatus should be disconnected from the mains completely before speaker wiring. The speaker output should be properly protected from direct contact and pay attention to speaker connections, terminals and speaker wiring during normal operation.

WARNING!

TO PREVENT FIRE OR SHOCK HAZARD, DO NOT USE THE PLUG WITH AN EXTENSION CORD, RECEPTACLE OR OTHER OUTLET UNLESS THE BLADES CAN BE FULLY INSERTED TO PREVENT BLADE EXPOSURE.
TO REDUCE THE RISK OF FIRE OR ELECTRIC SHOCK, DO NOT EXPOSE THIS APPLIANCE TO RAIN OR MOISTURE.

CAUTION

THESE SERVICING INSTRUCTIONS ARE FOR USE BY QUALIFIED SERVICE PERSONNEL ONLY.
TO REDUCE THE RISK OF ELECTRIC SHOCK DO NOT PERFORM ANY SERVICING OTHER THAN THAT CONTAINED IN THE OPERATING INSTRUCTIONS UNLESS YOU ARE QUALIFIED TO DO SO.



The lightning flash with arrowhead symbol, within an equilateral triangle, is intended to alert the user to the presence of uninsulated "dangerous voltage" within the product's enclosure that may be of sufficient magnitude to constitute a risk of electric shock to persons.

CAUTION

**RISK OF ELECTRIC SHOCK
DO NOT OPEN**

WARNING:

TO REDUCE THE RISK OF ELECTRIC SHOCK, DO NOT REMOVE COVER (OR BACK). NO USER SERVICEABLE PARTS INSIDE. REFER SERVICING TO QUALIFIED SERVICE PERSONNEL.



The exclamation point within an equilateral triangle is intended to alert the user to the presence of important operating and maintenance (servicing) instructions in the literature accompanying the appliance.



For European Union countries: This symbol on the product or its packaging indicates that this product must not be disposed of with other waste.

Instead, it is your responsibility to dispose of your waste equipment by handing it over to a designated collection point for the recycling of waste electrical and electronic equipment.

Please contact your local authority for further details of your nearest designated collection point.

Rating plate and caution marking are marked on the back enclosure of the apparatus



ENGINEERED BY AUSTRALIAN MONITOR
Address: 1 Clyde St, Silverwater NSW 2128 Australia.
Website: www.australianmonitor.com.au
International enquiries email: international@australianmonitor.com.au
ABN 35 007 573 417