



VC-LIN-EU WALL PANEL

VC-LIN-EU-W

The Australian Monitor VC-LIN-EU is a wall panel for remote volume control designed in a European/UK standard form factor.

A large rotary control with numbered positions (OFF, 1-10) provides intuitive, clearly referenced volume adjustment. The linear sweep potentiometer delivers smooth, consistent attenuation across the full travel of the control.

Connect the VC-LIN-EU to any compatible product with a Volume Controlled Attenuation (VCA) input.

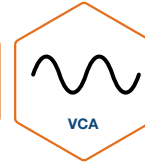

FEATURES

- Rotary volume control
- 500kΩ linear sweep potentiometer
- Remote VCA level control
- Compatible with Australian Monitor IS series power amplifiers
- European/UK standard form factor

VC-LIN-EU-W



WPBACKBOX-EU-W (optional)

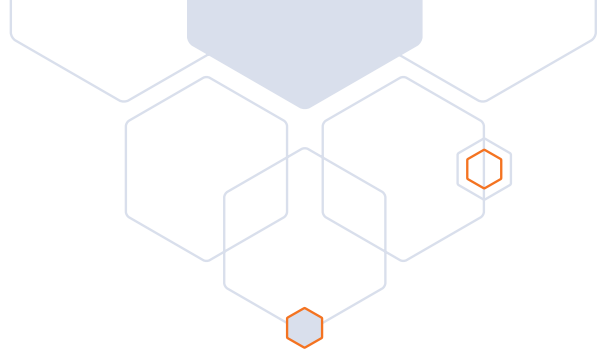

MODEL	VC-LIN-EU	COMMENTS
GENERAL		
USER CONTROLS	500k Ω linear potentiometer	
INPUT CONNECTOR	5mm, 2way screw terminal, 12-22AWG	
MECHANICAL		
PRODUCT DIMENSIONS	86mm x 42mm x 86mm (3.4"W x 1.7"D x 3.4"H)	
SHIPPING DIMENSIONS	156 x 132 x 101mm (6.1"W x 5.2"D x 4"H)	
NET WEIGHT	60g (0.13Lbs)	
SHIPPING WEIGHT	0.2kg (0.5Lbs)	
FINISH	ABS Plastic	
COLOUR	White	RAL 9010
OPERATING TEMPERATURE	0°C to 40°C (95% RH)	



LINE DRAWINGS

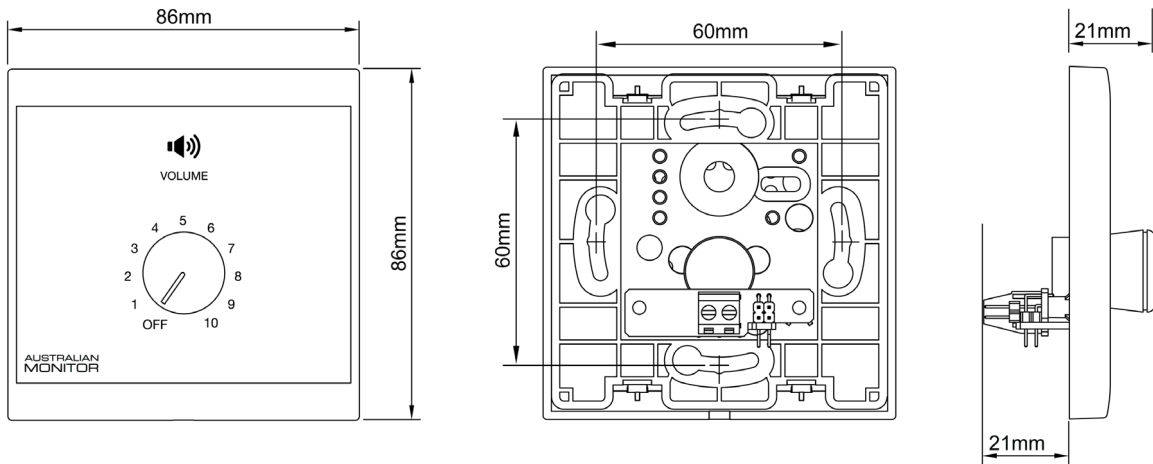

ENGINEERED BY AUSTRALIAN MONITOR

Address: Unit 1, 2 Daydream Street, Warriewood NSW 2102 Australia

Website: www.australianmonitor.com.au

International enquiries email: international@australianmonitor.com.au

ABN 86 003 231 187